

**A900**  
**TORNO TIPO LÁPIZ / PENCIL GRINDER**

MÁX. RPM / RPM MAX.: 58000

PRESIÓN TRABAJO / WORK PRESSURE: 6.5 kg/cm<sup>2</sup> (90 lb/pul<sup>2</sup>)

ENTRADA DE AIRE / AIR INLET: 1/4"

CONSUMO AIRE / AIR CONSUMPTION: 0.22 m<sup>3</sup>/min

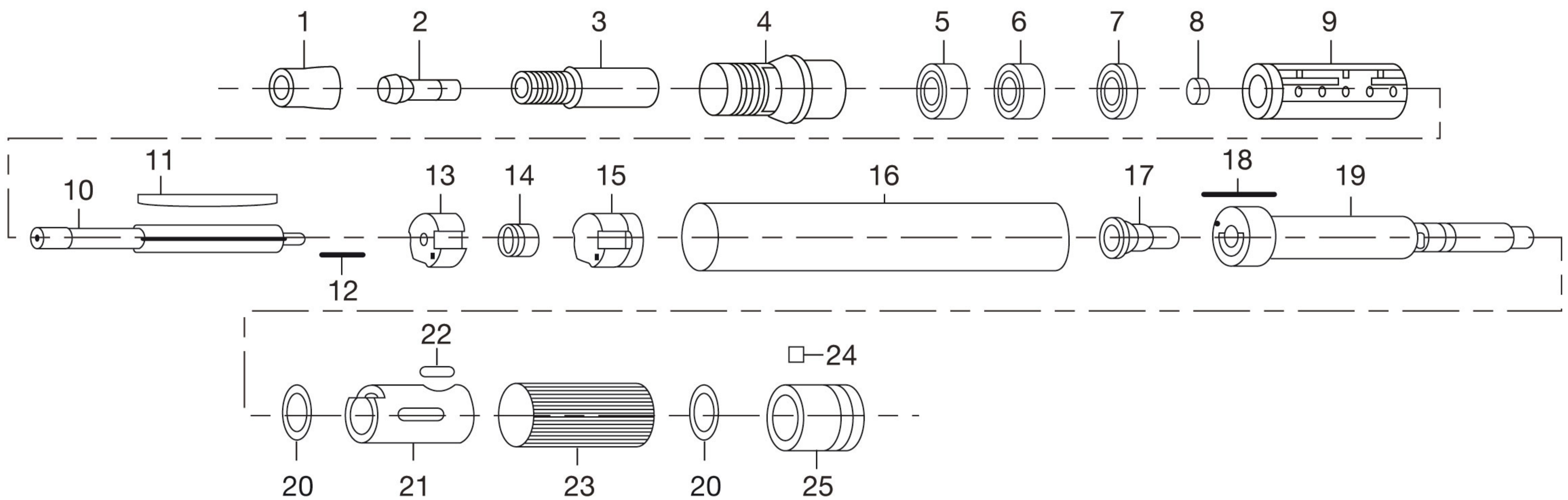

1	CLAMPING NUT	AJUSTA BOQUILLA
2	1/8" COLLET	BOQUILLA 3 mm
3	FRONT COVER	SOPORTE DE BOQUILLA
4	COLLET FONDATION	TAPA DELANTERA
5	BALL BEARING	RULEMÁN
6	BALL BEARING	RULEMÁN
7	SPACER	SEPARADOR
8	LATERAL DISC	DISCO LATERAL
9	CYLINDER	CILINDRO
10	ROTOR	ROTOR
11	FIBRE VANES (3 u.)	PALETA DE ROTOR (3 u.)
12	PIN	CHAVETA
13	BEARING PLATE	RULEMÁN PLANO
14	BALL BEARING	RULEMÁN
15	INTAKE PLATE	SOPORTE

16	SLEEVE	CUERPO PRINCIPAL
17	INTAKE TIE-IN	CONEXIÓN ENTRADA
18	PIN	CHAVETA
19	HOSE PLUG	ENTRADA DE MANGUERA
20	O-RING	ARANDELA "O"
21	KNOB IN-HOUSE SLIPCOVER	ACELERADOR
22	O-RING	ARANDELA "O"
23	SLIDING KNOB	MANDO DE VELOCIDAD
24	SCREW	TORNILLO
25	REAR END HOLDER	SOPORTE TRASERO